

12BB铸锭单晶PERC太阳能电池片

Cell appearance/电池外观

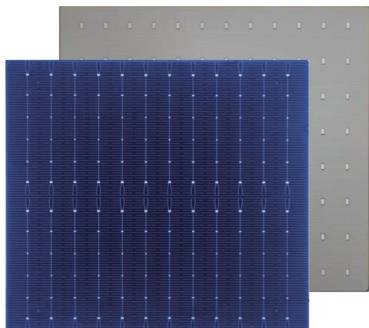

Appearance parameters/外观参数

项目/Items	规格/ Specification
Dimension/尺寸	158.75*158.75±0.25mm
Thickness/厚度:	190±30um
Front surface/正面:	12*0.1mm主栅线, 110根细栅线, 主栅头部为大双叉 二氧化硅+蓝色氮化硅复合减反膜 (PID Free)
Rear surface/背面:	背电极宽度1.6mm, 背面覆盖铝背场

Cell layout/网版图纸

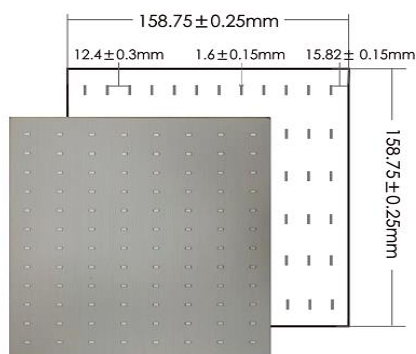
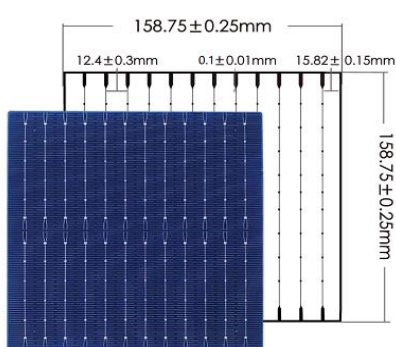

Adhesion and solderability/附着性及可焊性

Test items/检测项目

Adhesion of front/rear busbar/电极焊接拉力强度
Boiled Testing/背场可靠性:

Test requirement / 检测标准

180度角拉焊带 (无虚焊, 过焊等不良), 焊接拉力值 $\geq 0.5N$
电池置于 $75\pm 2^{\circ}C$ 水中煮10分钟, 试验中水不浑浊, 无铝层脱落

Light-induced degradation/光衰

Test items/检测项目

LID/光衰减:

Test requirement / 检测标准

辐照度不低于 $5kWh/m^2$, 功率衰减 $\leq 1.5\%$

Product advantages/产品优势

- 100%经过EL全检, 确保出货电池片无隐裂和断栅;
- 表面颜色均匀, 无印刷瑕疵, 外观美观;
- 低反向漏电流, PID工艺, 提高组件长期使用可靠性;
- 每档按照0.1%效率分选, 降低组件封装损耗。

Electrical performance/电性能

档位/Eff (%)	效率区间/Efficiency	功率/Pmpp (W)
22.4%	> 22.4%	5.65
22.3%	22.3~22.4%	5.62
22.2%	22.2~22.3%	5.59
22.1%	22.1~22.2%	5.57
22.0%	22.0~22.1%	5.54
21.9%	21.9~22.0%	5.52
21.8%	21.8~21.9%	5.49
21.7%	21.7~21.8%	5.47
21.6%	21.6~21.7%	5.44
21.5%	21.5~21.6%	5.42
21.4%	21.4~21.5%	5.39
21.3%	21.3~21.4%	5.37

Electrical properties/电特性

Temperature coefficient/温度系数

Voc: $-0.36\%/^{\circ}C$

Isc: $0.07\%/^{\circ}C$

Pm: $-0.38\%/^{\circ}C$

STC/标准测试条件

Intensity/光强: $1000W/m^2$

Spectrum/光谱: AM1.5

Temperature /温度: $25^{\circ}C$